



**Data Sheet**



Product Category: IF SAW Filter

Part Number 819-IF153.6M-A	Package 19 x 6.5 SMD	Application Base Station, Repeater, HDR, IMT-2000	Last Modified May 22 2003
-------------------------------	-------------------------	--	------------------------------

TYPE :  
153.6 MHz Bandpass Filter  
2.10 MHz Bandwidth

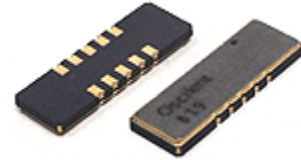

PART NUMBER :  
**819-IF153.6M-A**

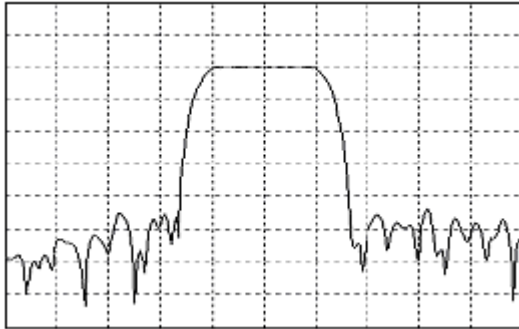

Horizontal : 1.0 MHz/Div  
Vertical : 10 dB/Div

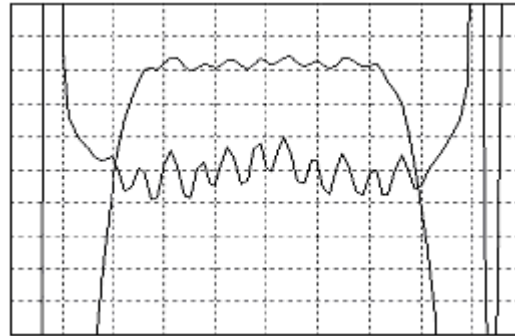

Horizontal : 0.4 MHz/Div  
Vertical : 1 dB/Div  
Vertical : 100 ns/Div

**OPERATING CONDITIONS / ELECTRICAL CHARACTERISTICS**

PARAMETERS	Minimum	Typical	Maximum	Units
Center Frequency	153.56	153.60	153.64	MHz
Insertion Loss	-	19.0	20.0	dB
1dB Bandwidth	1.80	2.0	-	MHz
3dB Bandwidth	2.10	2.30	-	MHz
30dB Bandwidth	-	3.30	3.50	MHz
Passband Ripple	-	0.45	0.60	dB
Group Delay Variation	-	190	220	nsec
Absolute Delay	-	2.20	-	µsec
Ultimate Rejection	40	45	-	dB
Substrate Material	-	Quartz	-	-
Ambient Temperature	-	25	-	°C
Phase Linearity	-	5.0	7.0	deg

\* Custom SAW IF Filters available. Contact Oscilent for assistance.

**PACKAGE OUTLINE (mm)**

**TEST FIXTURE**

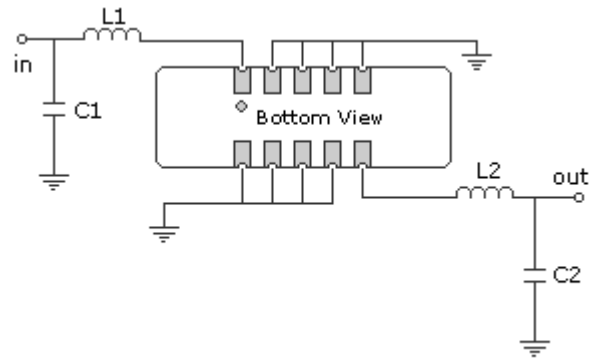
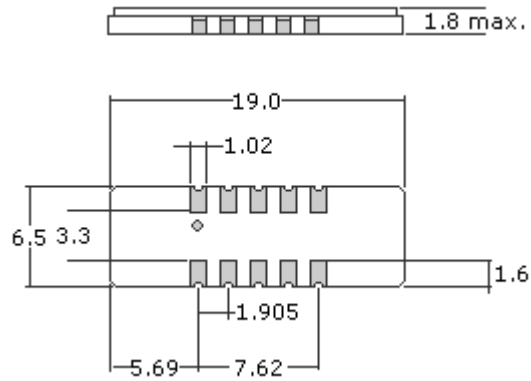

L1 = 78nH                      L2 = 68nH  
 C1 = 47pF                      C2 = 39pF  
 Source/Load Impedance = 50 ohms

**Oscilent Corporation** - CALL **949.252.0522**

17962 Sky Park Circle, Building D, Irvine, CA 92614, USA  
 Fax: 949.252.0599, E-Mail: Sales@Oscilent.com

**Part No.:** 819-IF153.6M-A

Crystal Oscillators | Quartz Crystal | TCXO | VCXO | IF SAW Filter | RF SAW Filter | Ceramic Resonator  
 Crystal Filter | Ceramic Filter | SAW Filter / SAW Devices | Site Map