



PRODUCT SPECIFICATION

REV O Dec 01 2016

Oscilent Controlled Document

Product Part Number	Product Description
1303-1590R-1840A-030-B02	Antenna

Contents

- o Part Number Builder
- o Package Dimensions
- o Electrical Specifications
- o Impedance Characteristics
- o Test
- o Environmental Testing
- o Caution of Use

Application

- o GPS
- o XM-Radios Satellites
- o BD+GPS
- o GPS+GLONASS
- o RFID
- o ETC
- o DSRC
- o RFID Tags



Oscilent Corporation
Telephone: 1.949.252.0522
Fax: 1.949.252.0599
Email: sales@oscilent.com



Part Number Builder

Series Number	Select Frequency	Polarization Mode	Dimensions + Type	Frequency Tolerance	Individual Specification
1303 –	1590	R	– 1840A	– 030	– B02
Structure	Enter Frequency	R = RHCP L = LHCP X = Linear Polarization	e.g. 1840 = 18x18x4.0 A = feeding pin position	015 = ±1.5 020 = ±2.0 025 = ±2.5 030 = ±3.0 050 = ±5.0 040 = ±4.0 100 = ±10.0 130 = ±13.0 150 = ±15.0 DF = Double Freq	Internal code for product structure, electrode shape, marking, and special parameters

Product Dimensions

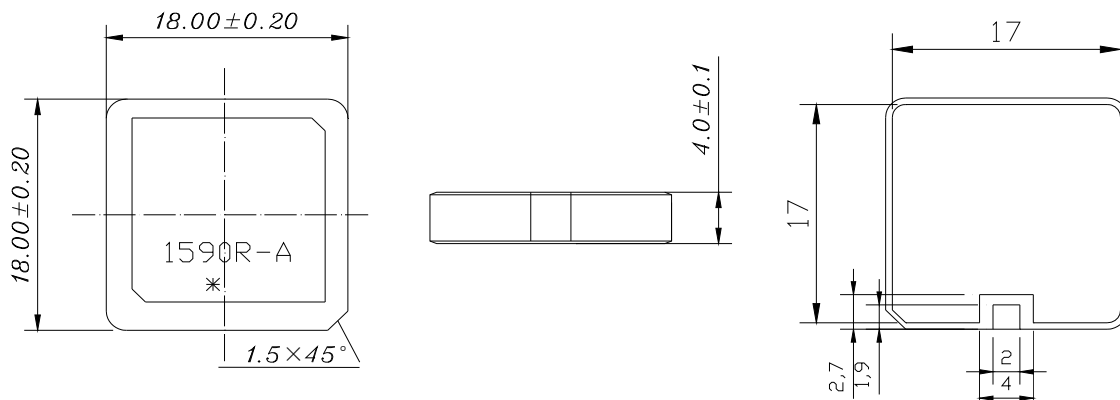

Electrical Specifications

Parameters Description	
Nominal Frequency MHz	1575~1608 (GPS: 1575, GLONASS: 1598~1608)
Center Frequency MHz*	1588.5.0±3.0
Return Loss at 1575 MHz max dB	-10
Return Loss at 1602 MHz max dB	-10
Impedance Ω	50
Polarization Model	RHCP
Permittivity	21
Frequency Temperature Coefficient	20ppm/deg.°C max

* Without adhesive tape on 50*50mm square ground plane

Impedance Characteristics

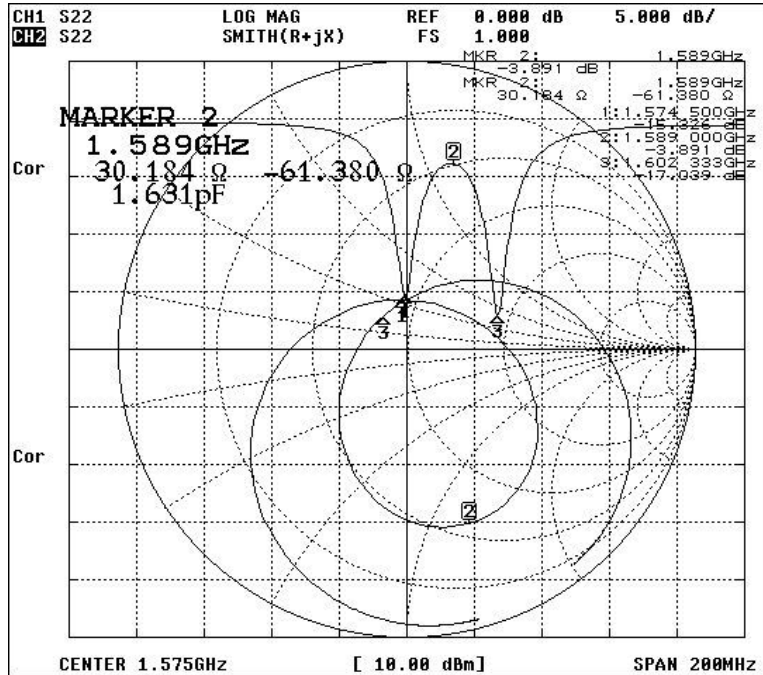

Test

Conditions: Measured under a condition (Temp.:20°C ±15°C, Humidity: 65%±20% R.H.).

Test Jig

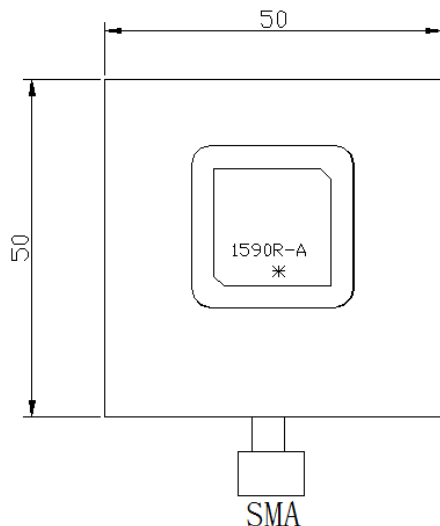



Environmental Testing

Item	Test Condition	Remark	
Humidity Test	Subject to 90%~95% relative humidity 60°C±3°C for 96h, then dry at 25°C±5°C, less than 65% relative humidity for 2h~4h.	It shall fulfill the specifications in Table 1.	
High Temperature Exposure	Satisfy the specification in table 1 after leaving at 105°C for 96h, measured within 2h~4h leaving in 25°C±5°C and less than 65% relative humidity.		
Low Temperature	Satisfy the specification in table 1 after leaving at -40°C for 96h, measured with 2h~4h leaving in 25°C±5°C and less than 65% relative humidity.		
Temperature Cycle	Subject the device to -40°C for 30 min. followed by a high temperature of 105°C for 30 min cycling repeated 5 times. At the room temperature for 1h prior to measurement.		
Vibration	Subject the device to vibration for 2h each in x, y and z axis with the amplitude of 1.5mm. Frequency shall vary uniformly between the limits of 10Hz~55Hz.		
Soldering Test	Lead terminals are heated up to 350°C±10°C for 5s±0.5s with brand iron and then element shall be measured after being placed in natural conditions for 1 h. No visible damage and it shall fulfill the specifications in Table 1		
Solder-ability	Lead terminals are immersed in soldering bath of 260°C~290°C for 3s±0.5s. More than 95% of the terminal surface of the device shall be covered with fresh solder.		The terminals shall be at least 95% covered by solder.
Terminal Pressure Strength	Force of 2kg is applied to each lead in axial direction for 10s±1s (see drawing). No visible damage and it shall fulfill the specifications in Fig 1		Mechanical damage such as breaks shall not occur.



Fig. 1

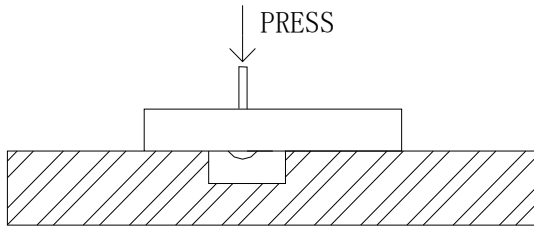

Table 1

Item	Specification After Test (MHz)
Center Frequency change	± 2.0

Caution of use

1. Do not apply excess mechanical stress to the component and terminals at soldering.
2. The component may be damaged when excess stress is applied.
3. This specification is based on the quality of the component as a single unit. Thoroughly evaluate the component in your application circuit.