



PRODUCT SPECIFICATION

REV O Dec 01 2016

Oscilent Controlled Document

Product Part Number	Product Description
1301-1590R-1540D-030-DD3	Antenna

Contents

- o Part Number Builder
- o Package Dimensions
- o Electrical Specifications
- o Impedance Characteristics
- o Test
- o Environmental Testing
- o Caution of Use

Application

- o GPS
- o XM-Radios Satellites
- o BD+GPS
- o GPS+GLONASS
- o RFID
- o ETC
- o DSRC
- o RFID Tags





Part Number Builder

Series Number	Select Frequency	Polarization Mode	Dimensions + Type	Frequency Tolerance	Individual Specification
1301 –	1590	R	– 1540D	– 030	– DD3
Structure	Enter Frequency	R = RHCP L = LHCP X = Linear Polarization	e.g. 1840 = 18x18x4.0 A = feeding pin position	015 = ±1.5 020 = ±2.0 025 = ±2.5 030 = ±3.0 050 = ±5.0 040 = ±4.0 100 = ±10.0 130 = ±13.0 150 = ±15.0 DF = Double Freq	Internal code for product structure, electrode shape, marking, and special parameters

Product Dimensions

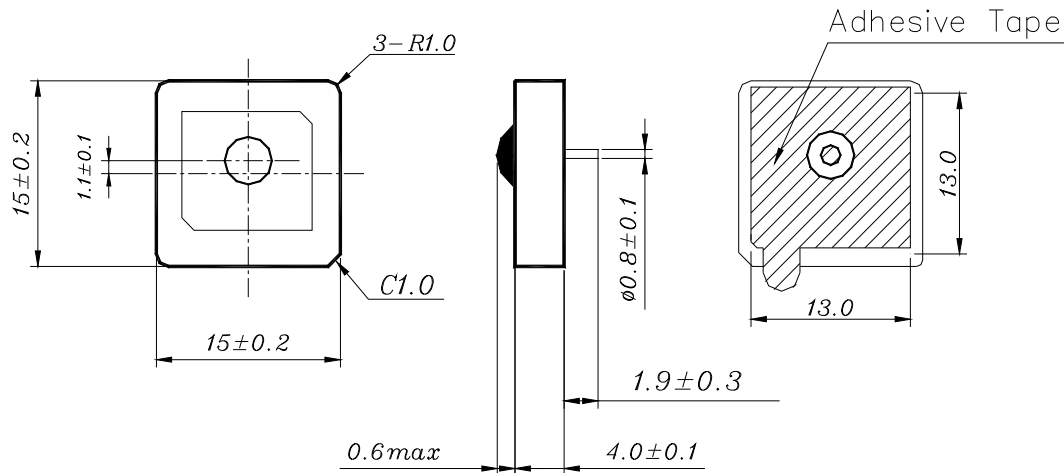

Electrical Specifications

Parameters Description	
Nominal frequency MHz	1575~1608
Center Frequency MHz*	1593±3.0
Real Part at CF	10±10 Ω
Imaginary Part at CF	10±10 Ω
Polarization Model	RHCP
Impedance	50 Ω

* Without adhesive tape on 35*35mm square ground plane

Impedance Characteristics

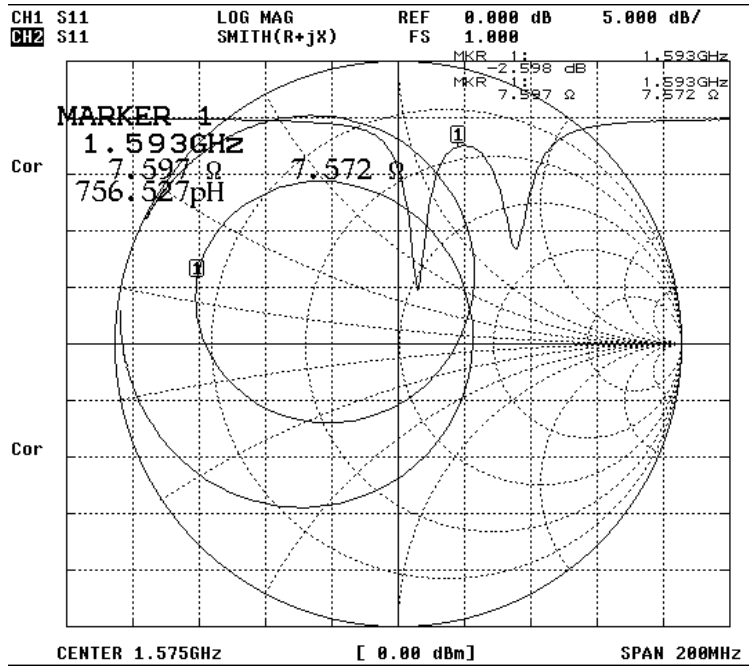

Test

Conditions: Measured under a condition (Temp.:20°C ±15°C, Humidity: 65%±20% R.H.).

Test Jig

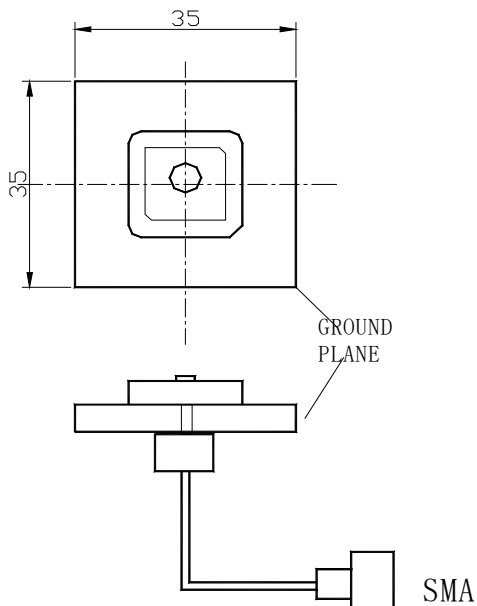

**Environmental Testing**

Item	Test Condition	Remark	
Humidity Test	Subject to 90%~95% relative humidity $60^{\circ}\text{C}\pm 3^{\circ}\text{C}$ for 96h, then dry at $25^{\circ}\text{C}\pm 5^{\circ}\text{C}$, less than 65% relative humidity for 2h~4h.	It shall fulfill the specifications in Table 1.	
High Temperature Exposure	Satisfy the specification in table 1 after leaving at 105°C for 96h, measured within 2h~4h leaving in $25^{\circ}\text{C}\pm 5^{\circ}\text{C}$ and less than 65% relative humidity.		
Low Temperature	Satisfy the specification in table 1 after leaving at -40°C for 96h, measured with 2h~4h leaving in $25^{\circ}\text{C}\pm 5^{\circ}\text{C}$ and less than 65% relative humidity.		
Temperature Cycle	Subject the device to -40°C for 30 min. followed by a high temperature of 105°C for 30 min cycling repeated 5 times. At the room temperature for 1h prior to measurement.		
Vibration	Subject the device to vibration for 2h each in x, y and z axis with the amplitude of 1.5mm. Frequency shall vary uniformly between the limits of 10Hz~55Hz.		
Soldering Test	Lead terminals are heated up to $350^{\circ}\text{C}\pm 10^{\circ}\text{C}$ for $5\text{s}\pm 0.5\text{s}$ with brand iron and then element shall be measured after being placed in natural conditions for 1 h. No visible damage and it shall fulfill the specifications in Table 1		
Solder-ability	Lead terminals are immersed in soldering bath of $260^{\circ}\text{C}\sim 290^{\circ}\text{C}$ for $3\text{s}\pm 0.5\text{s}$. More than 95% of the terminal surface of the device shall be covered with fresh solder.		The terminals shall be at least 95% covered by solder.
Terminal Pressure Strength	Force of 2kg is applied to each lead in axial direction for $10\text{s}\pm 1\text{s}$ (see drawing). No visible damage and it shall fulfill the specifications in Fig 1		Mechanical damage such as breaks shall not occur.



Fig. 1

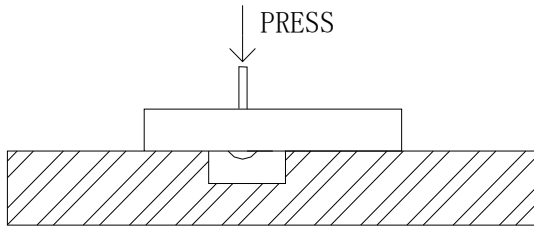

Table 1

Item	Specification After Test (MHz)
Center Frequency Change	±2.0

Caution of use

1. Do not apply excess mechanical stress to the component and terminals at soldering.
2. The component may be damaged when excess stress is applied.
3. This specification is based on the quality of the component as a single unit. Thoroughly evaluate the component in your application circuit.